

ML4066-QDD

Technical Reference

QDD-QDD Diagnostic Adapter



Table of Contents

Contents	2
1 Overview	3
1.1 ML4066-QDD Adapter Key Features	3
2 ML4066-QDD Pin Allocation	3
2.1 ML4066-QDD RevC	3
2.2 ML4066-QDD Rev B/A	4
2.3 Pins Diagram	5

1 Overview

The **ML4066-QDD** is a general purpose diagnostic adapter, which allows user to access all QSFP-DD controls, alarms and I2C signals, in addition to power nets, for testing purpose. A pin header connector, that breaks the connection between the “Plug connector” and “Host connector”, is used to access QSFP-DD pins individually, or when using jumpers, allows to connect plug connector to host connector pins, in addition to use this pin header to connect I2C analyzer.

1.1 ML4066-QDD Adapter | Key Features

- All high speed signals are connected from the QSFP-DD Plug to the front QSFP-DD host connector with superior SI traces
- Low insertion loss PCB traces
- Power pins are accessible via pin headers and can be jumped to connect them to the plugged QSFP-DD transceiver
- All low speed management signals are accessible via pin headers, and can be jumped to connect them to the plugged QSFP-DD transceiver
- I2C SCL and SDA signals accessible via pin headers or can be jumped to connect them to the plugged QSFP-DD transceiver
- Ability to drive I2C from external pin headers, or connect I2C packet analyzer
- Ability to drive 3.3 V from external source for power supply margining
- Ability to break 3.3 V power from Host to module allowing voltage and current measurement
- Interface to connect SFF Analyzer board

2 ML4066-QDD Pin Allocation

2.1 ML4066-QDD RevC

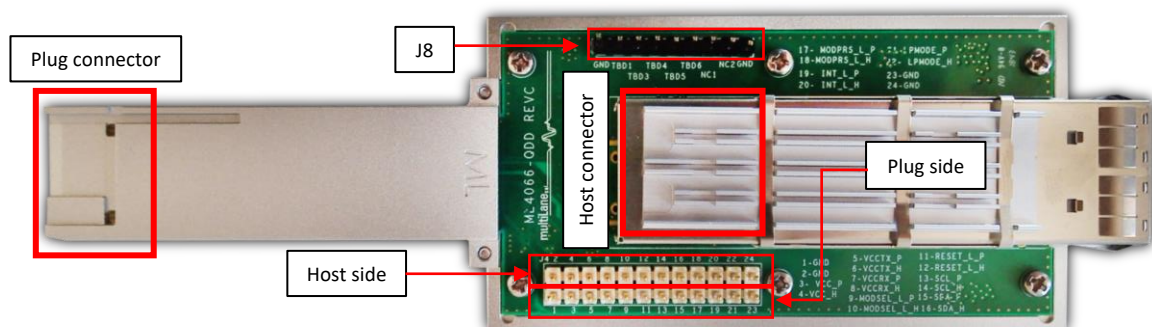

J8	
1	GND
2	Reserved
3	VS3
4	VS2
5	VS1
6	Reserved
7	NC1
8	NC2
9	GND

Pin Number (Host Side)	Host Side	Plug Side	Pin Number (Plug Side)
2	GND	GND	1
4	VCC_H	VCC_P	3
6	VCCTX_H	VCCTX_P	5
8	VCCRX_H	VCCRX_P	7
10	MODSEL_L_H	MODSEL_L_P	9
12	RESET_L_H	RESET_L_P	11
14	SCL_H	SCL_P	13
16	SDA_H	SDA_P	15
18	MODPRS_L_H	MODPRS_L_P	17
20	INT_L_H	INT_L_P	19
22	LPMODE_H	LPMODE_P	21
24	GND	GND	23

2.2 ML4066-QDD Rev B/A

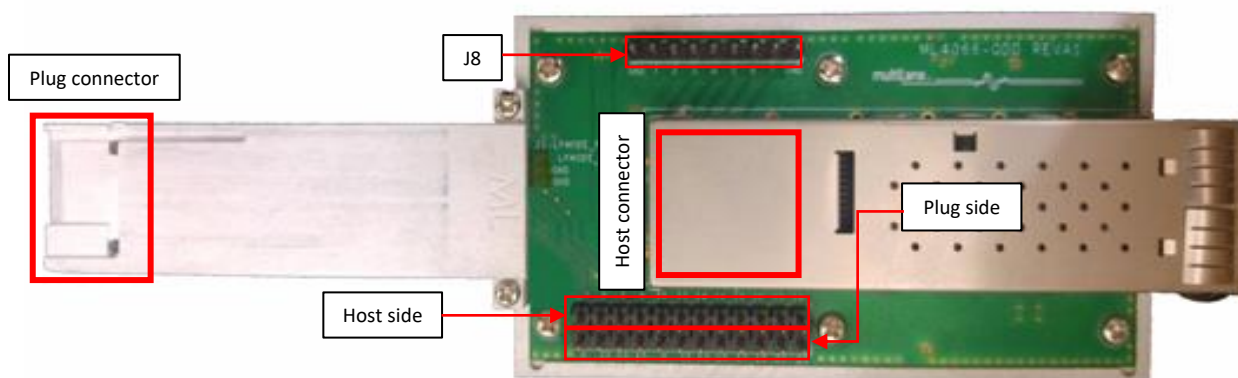

J8	
1	GND
2	Reserved
3	VS3
4	VS2
5	VS1
6	Reserved
7	NC1
8	NC2
9	GND

Pin Number (Host Side)	Host Side	Plug Side	Pin Number (Plug Side)
2	VCC_H	VCC_P	1
4	VCC1_H	VCC1_P	3
6	VCCTX_H	VCCTX_P	5
8	VCCR_X_H	VCCR_X_P	7
10	MODSEL_L_H	MODSEL_L_P	9
12	RESET_L_H	RESET_L_P	11
14	SCL_H	SCL_P	13
16	SDA_H	SDA_P	15
18	MODPRS_L_H	MODPRS_L_P	17
20	INT_L_H	INT_L_P	19
22	LPMODE_H	LPMODE_P	21
24	GND	GND	23

2.3 Pins Diagram

The adapter allows the user to make use of the pins to achieve a variety of different measurements as listed below:

- User can probe or drive the Host side
- User can probe or drive the Plug side
- User can place jumpers to connect the Plug side to the Host side.

To benefit from monitoring and diagnostic capabilities available in the GUI, plug the pin header into the ML4066-ANA-QDD Analyzer Board.

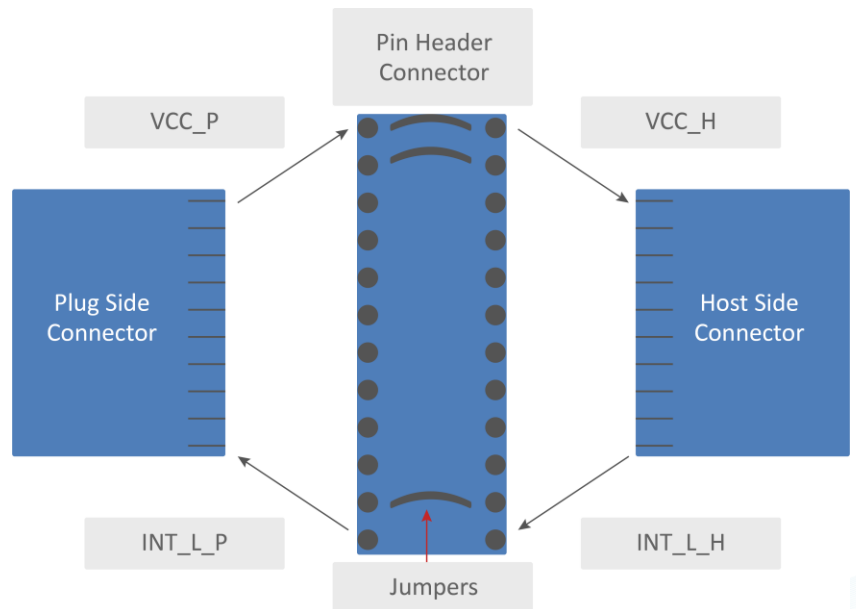

Revision History

Revision number	Date	Description
0.1	1/29/21	▪ Preliminary
0.11	10/14/21	▪ Format/language updates