

ML4062-MCB-MXP-ETH

Technical Reference

QSFP-DD MCB
MSA Compliant



Table of Contents

1	Overview	3
1.1	ML4062-MCB-MXP-ETH QSFP-DD Key Features	3
2	ML4062-MCB-MXP-ETH Hardware	3
2.1	Host Power-Up	3
2.2	Module Power-Up	3
2.3	Operating Conditions	4
2.4	Default Board Configuration	4
2.5	LED Indicators	5
2.6	Low Speed Signals	5
2.6.1	External I2C	5
2.6.2	External HW Control	6
3	ML4062-MCB-MXP-ETH Software	7
4	Hardware Revision	7
5	Firmware Revision	7
6	Bootloader	7

Table of Figures

Figure 1:	External Power Source	4
Figure 2:	Default Board Configuration	5
Figure 3:	I2C Pins	6
Figure 4:	Hardware Signals	6
Figure 5:	Low Speed Signals Schematics	6

1 Overview

The **ML4062-MCB-MXP-ETH** is designed to provide an efficient and easy method of programming and testing 400G QSFP-DD transceivers and active optical cables. It includes a complete user-friendly GUI supporting all features defined by QSFP-DD MSA and simplifying configuration processes to enable intuitive memory map programming and testing. It is designed to simulate an ideal environment for QSFP-DD transceivers module testing, characterization and manufacturing.

1.1 ML4062-MCB-MXP-ETH QSFP-DD | Key Features

- Supports 8x50G interfaces
- I2C master driven from both on board microcontroller or external pin headers
- 2x8 Huber+Suhner MXP Connector rows
- Current Sense
- Internal noise injection option through a programmable switching regulator
- Power margining between 3.1 V and 3.6 V
- Matched differential trace length
- All 8 channels come with matching trace length
- High performance signal integrity traces from MXP connectors to QSFP-DD host connector.
- On-board LEDs display MSA output alarm states
- On-board pin headers/jumpers for MSA input control signals
- User friendly GUI for I2C R/W commands and loading custom MSA memory maps
- Four corner testing capability
- USB interface
- Ethernet Interface

2 ML4062-MCB-MXP-ETH Hardware

The subsequent sections cover the essential parts in the hardware, for board operation and testing.

2.1 Host Power-Up

To power up the **ML4062-MCB-MXP-ETH** host, steps are as follow:

- The host TOP is where the cage is mounted
- Apply +5 V at the banana plug (U6)
- Connect the banana plug (U5) to GND
- Connect the host to your PC using a Type-B mini to Type-A USB cable.

2.2 Module Power-Up

The module is supplied using one of two power sources:

- From the on-board regulator that uses the main host supply (P5V) as input

- From an external 3.3 V source through connector (U319), by following the steps below:
 - Place a jumper between LDOS_OFF and P5V pins of U319 connector to disable the on-board regulator
 - Apply external 3.3 V at P3VX_HOST pins of U319 connector, as shown in the Figure 1.

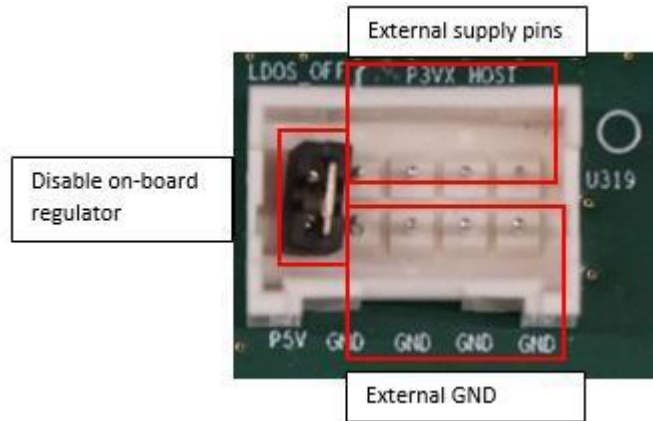

Figure 1: External Power Source

2.3 Operating Conditions

The input voltage supply must follow the table below.

Parameter	Symbol	Condition	Min	Typical	Max	Unit
+5	P5V	Supply from (U6)	-	5	-	V
+3.3	PIC_VUSB	Supply from (U319) P3VX_HOST	3.0	3.3	3.6	

Table 1: Voltage Operating Conditions

2.4 Default Board Configuration

The default operation of the board consists of the following:

- Module is supplied from on-board regulator:
 - LDOS_OFF pulled to GND
 - POWER_ON/OFF pulled to GND
- SCL, SDA, INT_L and MODPRS_L are pulled-up by placing the corresponding jumpers.

The image below shows the default jumpers placement for the low speed signals.

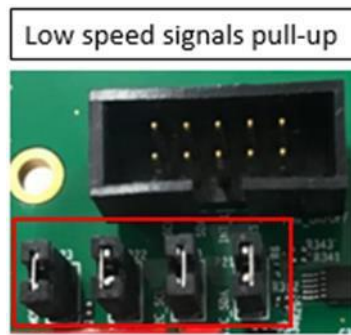

Figure 2: Default Board Configuration

2.5 LED Indicators

The **ML4062-MCB-MXP-ETH** includes on-board LEDs, for quick debugging and monitoring purposes. LEDs are summarized below:

- LED D10 for Ethernet operation.
- LED D3 indicates whether a USB cable is plugged or not.
- LEDs D2 and D4, colored green and red, respectively, are used for diagnostic purposes:
 - If D2 is on: USB is locked and device is recognized by the USB driver
 - If D4 is on: USB is not connected or USB driver is not found
 - If both are off: board is not powered correctly or firmware is corrupted
 - If both are blinking: the board is in Bootloader mode
- LED D8: LPMODE signal monitoring
- LED D19: RESET_L signal monitoring
- LED D16: INT_L signal monitoring
- LED D18: MODPRS_L signal monitoring
- LED D21: MODSEL_L

2.6 Low Speed Signals

2.6.1 External I2C

P20 and P21 are used to connect the pull up resistors for I2C SCL and SDA signals. The external I2C is driven through SCL and SDA pins of J7 Connector, shown in the image below.

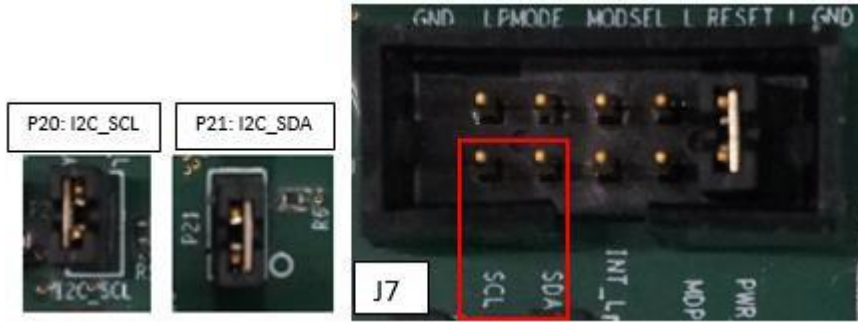

Figure 3: I2C Pins

2.6.2 External HW Control

All Hardware status and control signals of **ML4062-MCB-MXP-ETH** can be accessed through the pin headers connector J7, in addition to other HW pins at J18 pin header, as shown below.

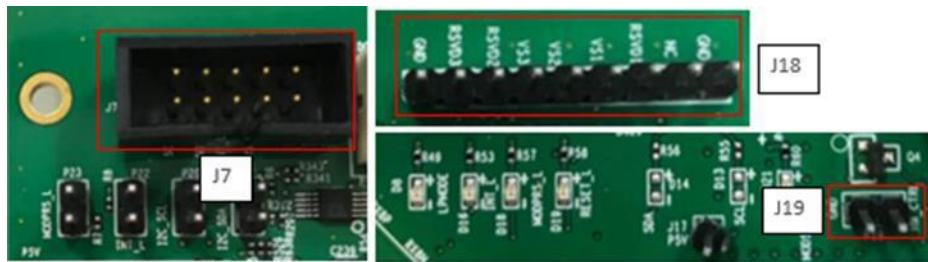

Figure 4: Hardware Signals

When a jumper is placed on P19 (HW_CTRL), the control signals can be accessed externally through pin headers shown above. In this case control signals are tri-stated in the microcontroller and controlled externally by the user.

The low speed signals circuit shown below shows the connection of these signals to the microcontroller and QSFP-DD connector.

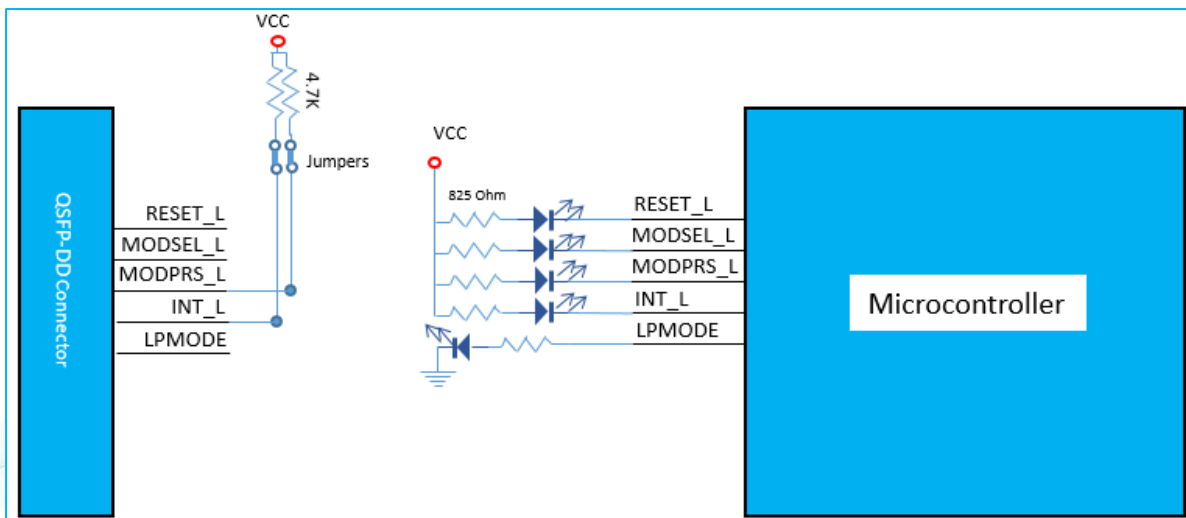

Figure 5: Low Speed Signals Schematics

3 ML4062-MCB-MXP-ETH Software

The **ML4062-MCB-MXP-ETH** is accessible and controlled through application software. This software is MSA compliant and provides a user-friendly interface to operate the board and access all its features. The communication between the ML4062-MCB-MXP-ETH board and the software is established through Ethernet connection.

4 Hardware Revision

- **ML4062-MCB-MXP-RevA1**: Initial Version
- **ML4062-MCB-MXP-RevB1**: DC-DC converter circuit fix

5 Firmware Revision

- **ML4062-MCB-MXP-RevB1_X_V1_1**: latest FW revision, compatible with the ML4062-MCB-MXP-RevB1 hardware.

6 Bootloader

Accessing in bootloader mode allows the user to reprogram the microcontroller, this is done as described below:

1. Connect a jumper on P15 (Boot Run) near the microcontroller.
2. Connect a USB cable between the PC and Board.
3. Power up the board.
4. LEDs (D2, D4) start blinking.
5. Remove jumper.
6. Open the software "Microchip USB HID Bootloader v2.3".
7. Click on "Open Hex File".
8. Choose the target FW to download.
9. Click on "Program/Verify".
10. Once the software finishes programming press on "Reset Device".
11. After reset the Firmware is successfully updated.

Revision History

Revision number	Date	Description
0.1	2/11/2020	▪ Initial Version
0.11	11/11/2021	▪ Format Change