

Solderless Board Mount Connector, 1.00 mm (F), Vertical Mount, Stripline

Package Contents

Connector	1 Pc
Screws	2 Pcs
Protection Cap	1 Pc

Connector Configuration

Connector	1.00 mm Female
Interface Type	Vertical Stripline

Materials

Description	Material	Finish
Center Pin	Beryllium Copper	Gold-Plated
Connector Body	Stainless Steel	Passivated

Electrical Specifications

Impedance	50 Ohms
Frequency Range	DC to 110 GHz
V.S.W.R.	1.063 max. at 110 GHz
Return Loss	-30 dB at 110 GHz
Insertion Loss	-0.059 dB at 110 GHz

Mechanical Specifications

Male-Female Mating Cycles	≥ 500 Cycles
Installation Cycles	100

Environmental Specifications

Operating Temperature Range	-55 to +165 °C
-----------------------------	----------------

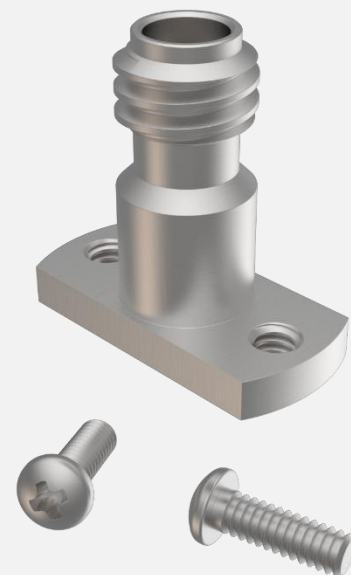

Features:

- Solderless
- Easy 2 Step Installation
- Compatible only with STL traces
- Compression Mount



Solderless Board Mount Connector, 1.00 mm (F), Vertical Mount, Stripline

How to Order:

Customer Part Number: **MLBMC-100FVSL-X**

X	Screw Length	PCB Thickness
4	4.76 mm	≤0.6 mm
6	6.35 mm	0.6 - 3.57 mm
9	9.53 mm	3.6 - 8 mm
11	11.13 mm	8 - 9.8 mm

Example:

PN: *MLBMC-100FVSL-4*

Description: *Solderless Board Mount Connector, 1.00 mm (F), Vertical Mount, Stripline, with 4.76 mm long Screws*

CAD Drawing

MLBMC-100FVSL-X

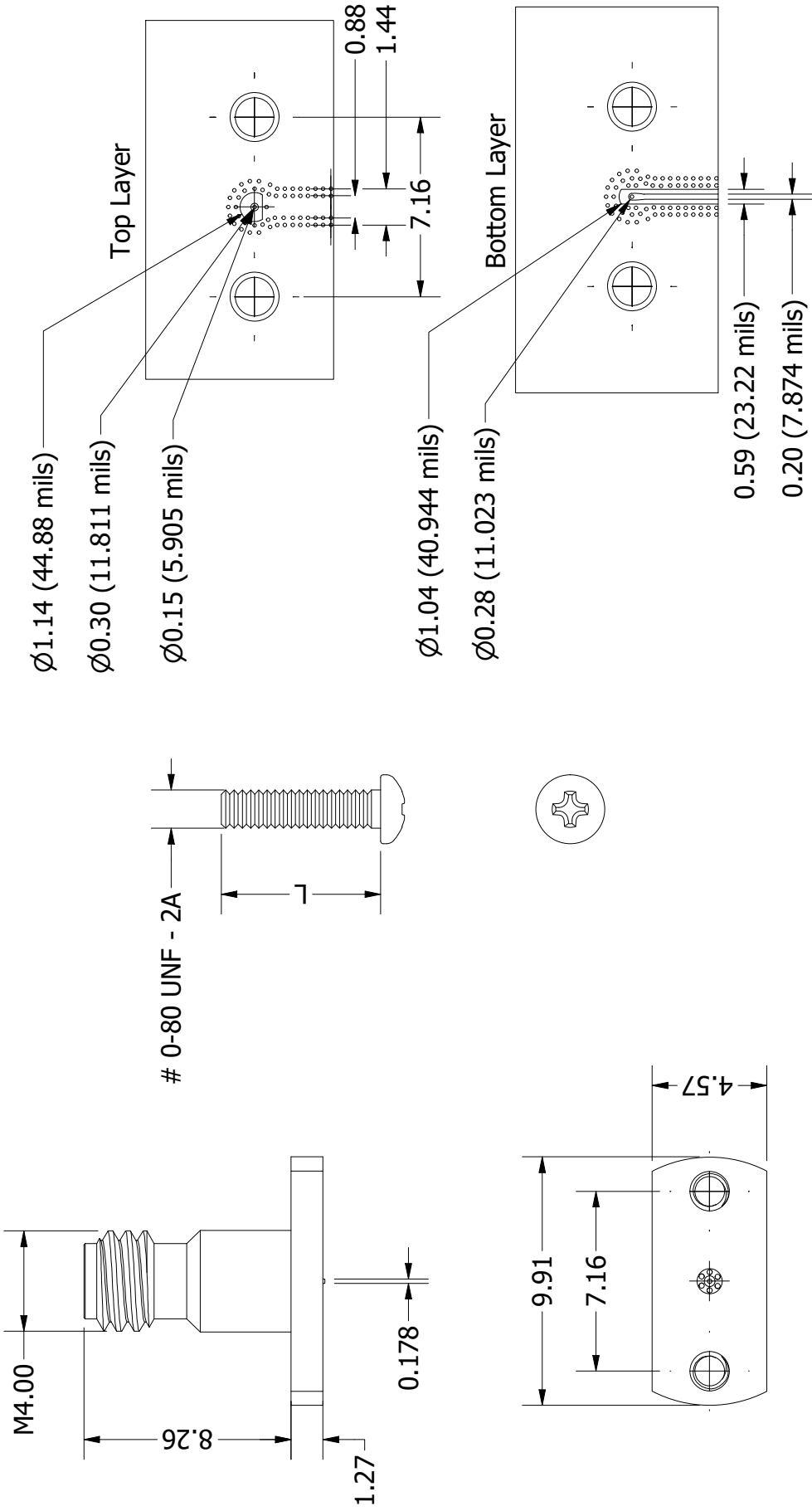

Recommended Footprint

Title:

Solderless Board Mount Connector, 1.00 mm (F), Vertical Mount, Stripline

Notes:

1. All dimensions are in millimetres unless otherwise specified.
2. These characteristics are typical and for reference.

multiLane

www.multilaneinc.com
sales@multilaneinc.com

Rev: A

Scale: 4:1